

# Development of an EDSS for the Management of the Hydraulic Infrastructure to Preserve the Water Quality in the Besòs Catchment

Francesc Devesa<sup>1</sup>, Peter De Letter<sup>1</sup>, Manel Poch<sup>1</sup>,  
Carles Rubén Díez<sup>2</sup>, Àngel Freixó<sup>2</sup>, Josep Arràez<sup>2</sup>

<sup>1</sup> Chemical and Environmental Engineering Laboratory (LEQUIA). Universitat de Girona.  
Campus Montilivi, s/n, Girona, 17071, Spain  
{francesc, peter, manel}@lequia.udg.es  
<http://lequia.udg.es/>

<sup>2</sup> Association for the Defense of the Besòs Catchment (*Consorti per a la Defensa de la Conca del Riu Besòs*, CDCRB). 241, Sant Julià avenue, Granollers, 08400, Spain  
{cr, afreixo,arraezej}@cdcbesos.org  
<http://www.cdcbesos.org/>

**Abstract.** In this paper we present the work done in the development of an Environmental Decision Support System (EDSS) to manage hydraulic infrastructures and to preserve the water quality in the Besòs Catchment. The Besòs Catchment (1038 Km<sup>2</sup>) is situated in Catalonia, in the north-east of Spain. As a pilot study, the project considers two sewer systems, their WWTPs, and a reach (17 km) of the Congost River. Infoworks CS, GPS-X and Infoworks RS were the chosen software to model the three main considered elements of the study area (sewer systems, WWTP and river). A rule-based expert system, representing the operation possibilities to solve typical problems (pick flows, load increases, etc.), is used to offer alternatives to the decision-maker. Alternatives are simulated with the different models and graphically represented in a GIS (ArcView software), that is part of the EDSS-Besòs interface.

## 1 Introduction

River basins or catchments are important social, economical and environmental units. They sustain ecosystems, are the main source of water for households, agriculture and industry, and fulfill many non-consumptive uses. Due to population growth, industry and overexploitation, the demands made on the river basin are increasing while the capacity of the basin to meet these demands is decreasing.

The recent European Union Water Framework Directive of December 2000 (Directive 2000/60/EC) imposed a new approach to water management. Some key elements of the Directive are: the protection of all surface waters and groundwaters must be assured, in their quality and quantity and with a proper ecological dimension; combined approach for the control of emissions and discharges should be considered; and, the best way to assure appropriate water management is a management system organized by river basin as a natural geographical and hydrological unit. Therefore, it

is clear that an integration of all the water problems at the scale of the river basin is seen essential by the European Union. Consequently, there is a need for integrated modeling at catchment scale.

Integrated management of a river basin is a very tricky business. The term integrated refers to various aspects necessary to consider in order to achieve sustainable development of river basins, including water demand and supply, trans-boundary aspects, upstream-downstream linkages, water and environment, development and environment, as well as organizational and institutional aspects at different scales (town halls, regional organs, industrial associations, ecological groups, etc.). To be able to process all the information available, to integrate and get all the different actors involved and to help the river basin managers in taking adequate decisions for every situation, classic tools have been shown to be poorly satisfying options. Therefore, there was the need to develop new tools. One of such tools is Environmental Decision Support Systems (EDSS). Several examples of EDSS have been proven very successful in managing and scoping a whole range of environmental problems [1,2,3,4,5,6,7] and more specifically on river basin management [8,9,10,11,12,13,14].

The aim of this paper is to represent a methodology to build and operate such an EDSS to manage the Besòs catchment, a river basin near Barcelona in the north of Spain.

## 1.1 Study area

The Besòs Catchment (1038 Km<sup>2</sup>) is situated in Catalonia (north-east of Spain) (Fig.1). The catchment has a typical Mediterranean hydrological pattern, with very low dry water flows (near 2 m<sup>3</sup>/s at his mouth), but the flow can increase up to 1000 times in the autumn rainfall periods. This is one of the most populated catchments in Catalonia, having more than 2 million people connected. Nowadays there is a very high industrial activity, situated near the Besòs River, covering almost all the industrial sectors: chemical, metallurgic, textile, construction, food, paper, etc.

The project location is around the final reaches of the Congost River (an effluent of the Besòs River). The river sustains, in an area of 70 Km<sup>2</sup>, the discharges of 4 towns (*La Garriga, Les Franqueses del Vallès, Canovelles* and *Granollers*), which are connected to two Waste Water Treatment Plants (WWTP). The total population connected reaches up to 100000 inhabitants.

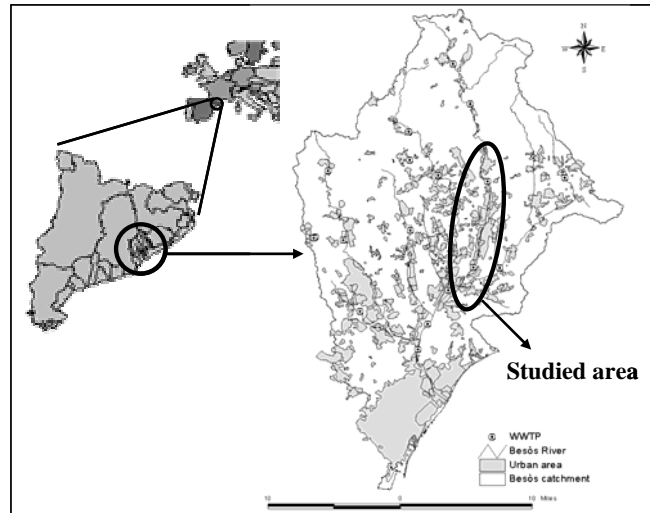

Fig.1. Studied area location

## 1.2 Main elements of the system

The real system is divided in three main elements: sewer system, WWTP and river. Each of them is modeled with specific software. Every element is then subdivided, at modeling level, in calculation units. Typical examples of these units are an overflow in the sewer system, a reach of a river or the primary settler in the WWTP. It is considered that each calculation unit has the same hydrodynamic characteristics (Fig.2).

**Sewer system.** There are two sewer systems, one that drains the area of the town *La Garriga* and another one that drains the area of *Granollers* and some small surrounding villages. The total drained area is around 2100 ha, of which about 750 are impervious. During heavy rain events several combined sewer overflows spill diluted wastewater directly in the Congost River.

**WWTP.** There are two WWTP, one for each sewer system. The two plants have a biological treatment. The average flows are 6000 m<sup>3</sup>/d for the La Garriga-WWTP and 26000 m<sup>3</sup>/d for the Granollers-WWTP.

**River.** The studied reach of the Congost River has a length of 17 km. The Congost is a typical Mediterranean river with seasonal flow variations. Before the two WWTP, the average flow is about 0.5 m<sup>3</sup>/s, but can easily reach a maximum punctual flow of 200 m<sup>3</sup>/s.

Moreover, apart from these three elements, others are considered (rain control stations, river water quality control stations, flow retention and storage tanks, etc.);

but the most essential one is the sewer channel that joins the two WWTPs. This channel allows to by-pass the flow from the La Garriga-WWTP to the Granollers-WWTP, which means the amount of manage possibilities in the whole system increases considerably (Fig. 2).

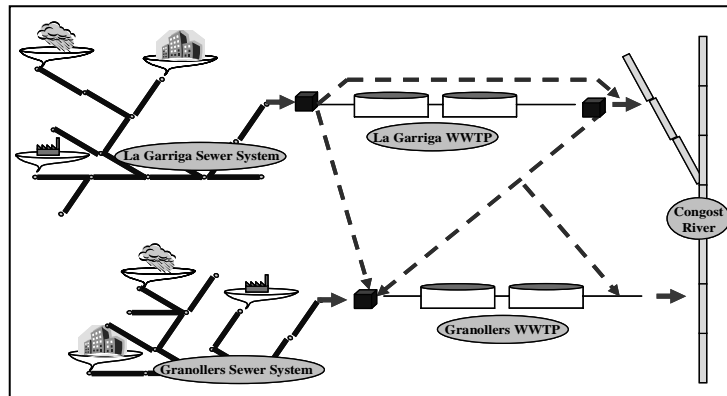

Fig.2. Main elements of the system

## 2 Besòs-EDSS building

We define an EDSS as an integrated system of tools that improve the decision making process in the environmental field: “An EDSS is an informatics system that helps a person to make decisions in a determined scope, by means of the justified selection of one or more alternatives” [1,2,3,15]. This EDSS definition is generally used, differing slightly from author to author.

### 2.1 General architecture

How a particular EDSS is constructed will vary depending on the type of environmental problem and the type of information and knowledge that can be acquired. With these constraints in mind, and after an analysis of the available information, a set of tools can be selected. Numerical models are used to simulate the real problems and their alternatives solutions. Artificial intelligence (AI) methodologies are included to represent the expertise knowledge. Models selected are then implemented and integrated in the EDSS (Fig. 3).

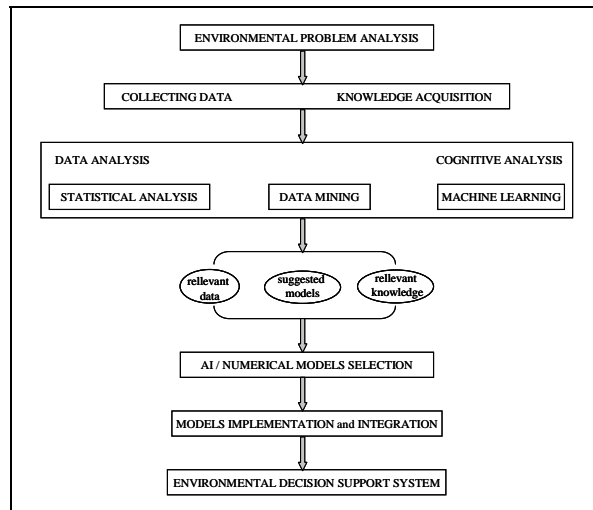

Fig. 3. Flow diagram for development of an EDSS. Modified by [1]

## 2.2 Problem analysis

The Association for the Defense of the Besòs Catchment (*Consorti per a la Defensa de la Conca del Riu Besòs*, CDCRB) is the entity that manages the sewer systems and WWTPs. As managers, the CDCRB has to treat the sewer water in accordance with the legislation. It has to guarantee that poorly-treated waters are not spilled into the river but, at the same time, has to optimize the economical costs of the treatment. The majority of the sewer system is combined (receives the waste water and the rain water through runoff). Furthermore, many industries are connected to the system, implying an irregular profile of flows and loads arriving at the WWTP. All these facts make it difficult to carry out the obligations of the CDCRB. To deal with these problems, the CDCRB and the University of Girona are implementing the EDSS-Besòs, a tool that has to facilitate the management of the infrastructures, guaranteeing the water quality of the river. The CDCRB manages 14 WWTPs and their sewer systems in the whole Besòs Catchment, but the project is focused on the final reach of the Congost River, as a pilot study.

**Objectives.** The Besòs-EDSS project was born to solve the typical situations which appear managing the hydraulic infrastructures of the catchment. From this point on, and taking into account the EDSS capabilities, more challenges were added.

The main objectives of the Besòs-EDSS are:

- To dimension the flow derivations between the different sewer systems.
- To locate and dimension storage tanks, that will be used to regulate flow and loads, critical pollution episodes, and rain events.

- To locate and dimension future increases of the system capacity (hydraulics, treatment, pipes).
- To locate the control points of the sewer system.
- To operate the whole system.
- To manage critical episodes.

These objectives have to be carried out taking into account some limitations. These limitations are:

- To maintain a minimum flow guaranteeing an acceptable ecological state in the river.
- To minimize the discharges of poorly treated wastewaters.
- To maximize the use of the installations treatment capacity.
- To minimize the economical costs of new investments and daily management.

### 2.3 Collecting data and knowledge acquisition

To construct the models of the two sewer systems different types of data were required. Physical data (slopes, heights, volumes of the manholes and conduits, etc) was introduced through a Geographic Information System (GIS) data base. Other information (meteorological data, industrial spill locations and their water quality characteristics) were introduced manually. All this information was provided by the CDCRB. Other types of data as water consumption and pollutant generation per capita were found in the literature.

Physical and operational data of the WWTP has been provided as well by the CDCRB. Kinetic and stoichiometric parameters have been found in the literature. Water quality sample controls were done periodically in the influents and effluents of the WWTPs. These data have been considered and analyzed.

Physical, hydrodynamic and meteorological data of the river have been extracted from the Catalan Water Agency (*Agència Catalana de l'Aigua, ACA*) and the CDCRB. The flow and water quality data has been provided by the ACA, who has installed water control stations in the river.

Different experts (WWTP and sewer systems managers, river water quality controllers, etc) have contributed with general knowledge (through personal interviews), above all, of the most common problems that can appear in the studied area.

### 2.4 Models selection

**Expert system.** Once a problem is detected, the EDSS has to provide an alternative to overcome the situation in the best possible way. To build a set of actuation alternatives a knowledge base has to be developed. Literature reviews, expert interviews and model simulations are the sources to concretize the most common

problems and their solutions. To represent and to transmit the compiled knowledge to the EDSS, a rule-based system model was chosen.

Rule-based systems offer a number of advantages that overcome some of the limitations of other artificial intelligence techniques: They facilitate the inclusion of heuristic knowledge from experts and allow the processing of qualitative information; knowledge is represented in an easily understandable form (rules). Moreover, a well-validated ES offers potentially optimal answers because action plans are systematized for each problematic situation. Finally, ESs make the acquisition of a large general knowledge base possible [1]. In contrast, rule-based systems do not have an ability to learn from the experience. Only a human expert who knows how the rules are constructed can modify the knowledge base.

**Mathematical models.** Another step is the selection of the simulation software. Each alternative given by the ES has to be tested with a simulation that evaluates the possible consequences of the action. Therefore, we need models that represent the three elements of the real system (sewer network, WWTP and river) in an approximate way.

The model selection process has followed a standard protocol (Fig. 4).

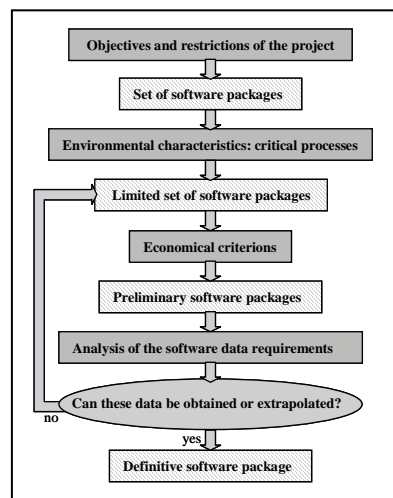

Fig. 4. Model selection protocol

The first step was to define the objectives and restrictions of the project. In this way, together with other features, a group of software packages were selected, which are capable of modeling at least ammonia, Biochemical Oxygen Demand (BOD), Dissolved Oxygen (DO), and temperature. From this group of software packages, those which do not model a critical process of the basin (i.e. runoff) were discarded. Furthermore, two more key features were considered in the selection process: good

communications between models and our previous modeling background. We took into account the time, as another restriction to develop the project, and we considered that we could reduce the model-learning time if we chose a known model. As a consequence Infoworks Collections Systems (CS), GPS-X and InfoWorks River Simulation (RS) were the three elections.

Whenever different model types with different modeling detail are compared, the most appropriate model to meet the project objectives must have an optimal balance between uncertainties resulting from model assumptions and uncertainties resulting from the data. The balance therefore depends on data availability, as the optimal model detail and also the model accuracy increases with increasing data, although implementation costs will also increase [16]. So, as a last step, the chosen model software was compared to the data availability to arrive at the final acquisition of the software packages.

*Sewer system.* Both sewer systems have been modeled using InfoWorks CS from Wallingford Software Ltd. InfoWorks CS manages sewer network models, containing both network and hydraulic data. Modeling of pollutants is fully conservative. There is no interaction between pollutants and their environment, or between one pollutant and another. However, the InfoWorks CS water quality model allows simulating the built-up of sediment in the network and the movement of sediment and pollutants through the drainage system during a rainfall event. Pollutant and sediment can enter the model from a number of sources (Fig. 5) [17].

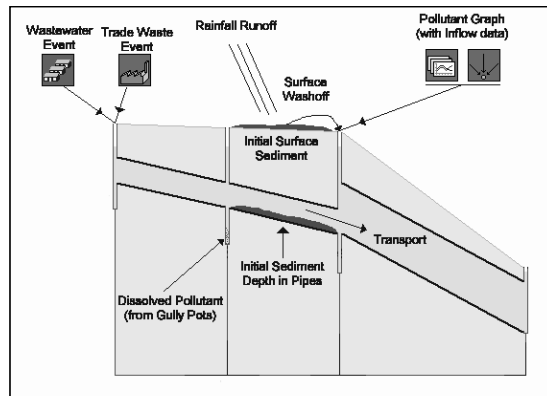

Fig. 5. Components of the water quality module

*WWTP.* Both WWTPs have been modeled using GPS-X software from Hydromantis, Inc (Fig. 6). GPS-X is a very powerful simulator for dynamic simulation of wastewater treatment systems. GPS-X is supplied with a large number of models covering virtually all the unit processes found in wastewater treatment plants, including advanced nutrient removal models, fixed-film operation, anaerobic reactors, secondary settler models, primary settler models and several units for sludge

operation. The simulator is built on the ACSL simulator and on top of the off-line capabilities GPS-X can download on-line data automatically from a SCADA system [18].

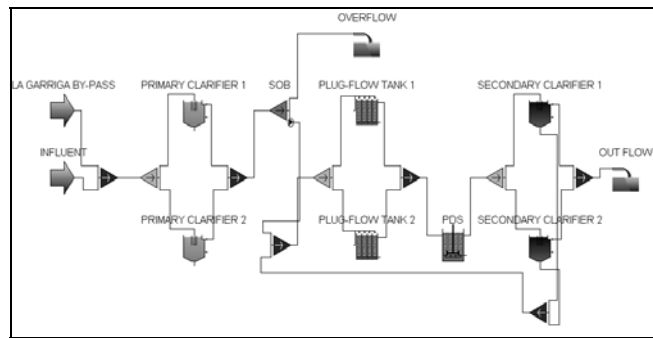

Fig. 6. Layout of the Granollers WWTP in GPS-X

*River.* The river has been modeled using InfoWorks RS software. InfoWorks RS models the key elements of the river hydrodynamically. The software contains a quality simulation engine, which is separated from the hydraulic engine. InfoWorks Water Quality computes concentrations using a finite difference approximation to the advection-diffusion equation. Although InfoWorks Water Quality is a depth averaged model, for mud transport and water quality, an element is divided into four vertical sub-components (Fig. 7):

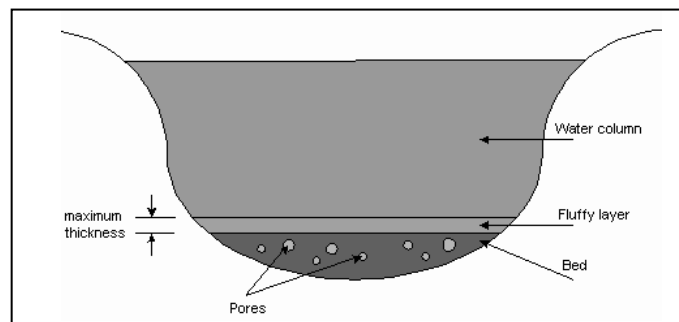

Fig. 7. Vertical structure of the model

- Water column. This is the main body of water through which dissolved and suspended substances are transported.
- Bed. This represents the consolidated mud that has settled out of the water column and can be re-suspended.

- Fluffy layer. This is a layer of mud that lies on top of the consolidated bed and is less dense. Settled matter initially falls into this layer. It is limited to a maximum thickness. Once the layer has filled to its maximum thickness, any additional settled material causes an equal amount to pass into the bed.
- Pore water. As mud consolidates into the bed layer, water is trapped within its pores. The rate of transfer of dissolved substances into the pore water is proportional to the deposition rate [17].

*Geographic Information System (GIS)*. All the geographic information is georeferenced and can easily be displayed in the EDSS-Besòs GIS. The link between the sewer system and river models and the ARCVIEW GIS software package is not problematic, and can be used to represent the simulation results graphically. Thus, the GIS can be used as a part of the interface between the user and the EDSS.

## **2.5 Models integration**

Different problems are encountered when developing an integrated model that is to be used to develop an integrated control system. First, the state-of-the-art models use different variables to describe the aquatic system. Second, these models are typically implemented in different software packages, making simultaneous simulations difficult to achieve, since communication typically requires file transfer from upstream to downstream. Furthermore, the flow of information about the downstream state to the upstream models, which is necessary for an integrated control action, is even more complicated or even impossible [19].

Bearing in mind these considerations, taking into account that a reliable connection between the models is difficult yet essential, a firm EDSS operational system is needed to connect automatically the three models.

The model integration presented in this project doesn't imply a parallel running model. Serial running is used. Each down-stream model is run afterwards with input files from the other parts. In this way, the WWTP model receives the output from the sewer model and can receive the output from another WWTP too. The river model receives the output from the WWTP models and the outputs from the sewer models (when the overflows work in a rainfall event). In a preliminary phase, an external program has been designed using the Delphi programming language to transfer the output files between the different software packages.

A main problem of integrated models is that they possess many uncertainties. These include measurement and sampling errors in data inputs and other data used to calibrate the models, model structure assumptions, model parameter values and assumed constants. Some of these errors can accumulate as simulations progress sequentially, as outputs of one model are used as inputs to another [20]. In our case, this can occur through spatial cascading along catchment calculation units.

## 2.6 Validation

Once the models are calibrated and validated on the basis of real data, extra simulations can be performed with these models in order to generate extra virtual data [19]. After having validated the hydraulic model, the water quality module has to be confronted, contrasting simulated and real data. In this case, the calibration level will depend on the quantity and reliability of the historic water quality analysis. When the three models are calibrated and ready to carry out any simulation, we have to actualize simulation data from the control stations.

## 3 EDSS operation

In our case, we need to actualize data continuously from the real system. For this reason we implement different modules of data acquisition (river flow, sewer system discharges, WWTP discharges, rain, etc.) to maintain the simulations in more realistic conditions (Fig. 8). This data, together with other information (hydraulic, physical, climatological, etc.) about the different elements of the system, is used by the models to simulate the majority of the situations that can appear in the whole system. Once obtained a simulation of the actual or a future situation, the system provides information about the possible consequences at different levels (water quality, flow, infrastructures, etc.). Then, the system requires an expert system (ES) to produce valid actuation alternatives. After evaluating the alternatives with different simulations, the user will finally decide the best one. At the end of the process the system will give the sequence of the specific actions needed to develop the alternative.

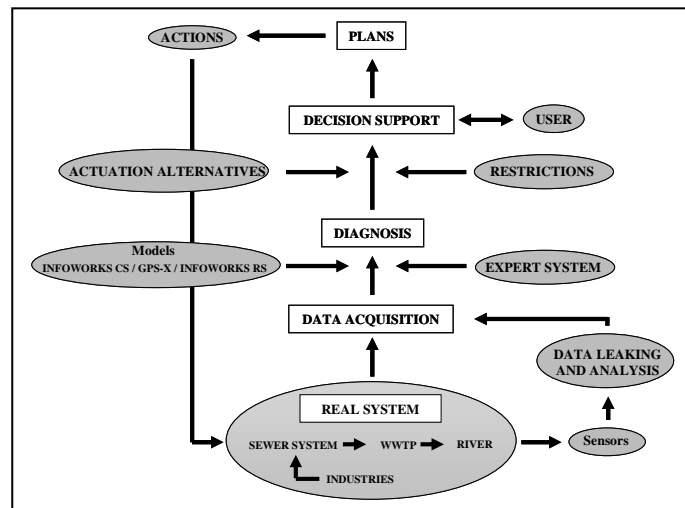

Fig. 8. EDSS-Besòs operation

The EDSS-Besòs can operate at two levels. The first, “scenarios simulation level”, is used to predict future changes in the system in water quality, flow directions, loads, etc. A typical use of this level is to assess the best location for new infrastructure (i.e. a storage tank) or to estimate which water quality impact will have a new spill on the river. The second level, “general system operation”, is used to control the more frequent decisions that the EDSS manager has to take. Examples are to hold certain flow at the storage tanks when it rains or to bypass flow from the upstream WWTP to the downstream one to improve the treatment efficiency.

Consequently, the action sequence will be different depending on at which level the EDSS is operating.

### 3.1 Scenarios simulation level

This level can be seen as a planning level where the user wants to investigate the future consequences of changing or building new infrastructures.

To go on with the example of building storage tanks to ensure a laminar flow in the influent of the WWTP, the action sequence to be carried out with the help of the EDSS is the following:

- 1 To assess the actuation alternatives characteristics (storage tank volume, best emplacement, time control of the re-spill to the sewer system, etc.).
- 2 To set up the actuation alternatives in the model system. The physical characteristics of the storage tanks are introduced in the sewers model.
- 3 To simulate the different evaluated alternatives. Each alternative is simulated, collecting all the hydrodynamic and water quality results (Fig. 9, Fig. 10).
- 4 To interpret the results considering the established criterions (minimum economical cost, maximum infrastructures performance, minimum ecological impact in the river, accordance with legislation, etc).
- 5 To select the most appropriate decision.

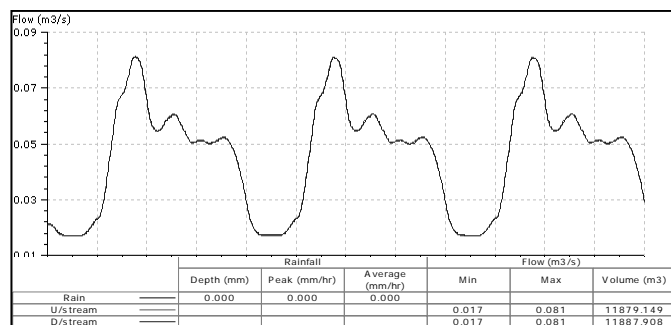

Fig. 9. 3-days profile of a non laminated flow at the La Garriga WWTP

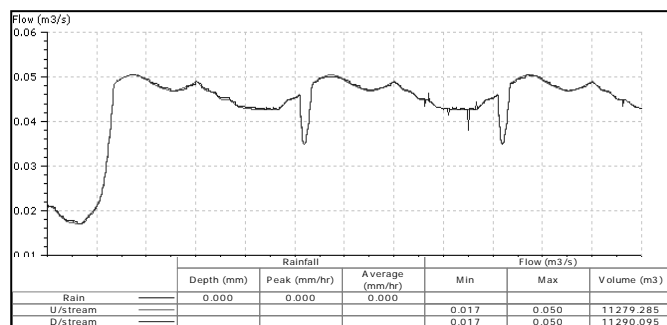

Fig. 10. 3-days profile of a laminated flow at the La Garriga WWTP

### 3.2 General system operation

The actions sequence managed by the EDSS in a typical situation (i.e. rain producing a peak flow) is the following:

- 1 To detect the problem. A rainfall control station situated in the sewer system sends an alarm message.
- 2 To asses if the rainfall is critical. The ES evaluates the rainfall intensity and provides the actuation alternatives: no actuation, partial flow-by pass to another WWTP, storage tank retention, etc.
- 3 To simulate the actuation alternatives with the model system.
- 4 To evaluate the economical cost of each alternative, their influence in the river water quality (Fig. 11) and the performance of the infrastructures utilization.
- 5 To propose the best alternatives also considering the restrictions and the legislation.
- 6 To interact with the user, who will take the decision.
- 7 To give the list of specific actions to carry out the taken decision.

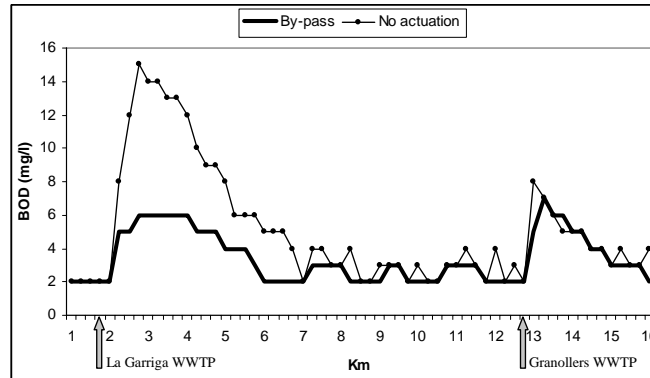

Fig. 11. Congost BOD concentration depending on the alternative actuation

## 4 Discussion

Traditionally, water quality problems at catchment scale have been confronted individually, without bearing in mind its causes upstream or consequences downstream. Furthermore, the water manager organism is frequently different for each water system (sewer system, WWTP or river) and for each municipality, which complicates the integrated management. The existence of a tool that makes the interaction between the water systems and water managers possible, grouped under a sole decision maker, helps to optimize the water quality management. In this way, if a solution to a water quality problem seems very easy at local scale within one element of the system, but affecting negatively another element of the system, it will not be considered as a valuable solution by the EDSS. However, this doesn't mean that the EDSS-Besòs will be automatic and independent in such a way that it could replace the decision maker. More precisely, the EDSS-Besòs assists the water manager providing a set of possible actuations to solve water quality problem. Since the EDSS can consider the economic cost of each actuation, an analysis benefit-cost of the actuations can be made, adding this parameter as a limiting criterion. Again, this is only possible if the decision maker is the manager of the whole system.

A high variation of models has been detected during the selection process, varying from detailed physically-based models to simplified conceptual and empirical models. The software chosen in this project has the capability to construct detailed full hydrodynamic models. More simplified models are appropriate for long-term simulations or for at large scale level (big catchments). However, the objectives of the study, in the "general system operation" level, can be achieved with short-term simulations and at small catchment scale.

Selection of adequate models, its integration and the generation of rules that represent the possible water quality problems and their solutions are the core of the EDSS-Besòs building process. These phases will determine the subsequent EDSS applicability to other catchments. The model software chosen in this project is generally applicable to any catchment. Therefore, the model integration work done in

this study will easily be exported to other areas. However, the ES will probably have to be modified to adapt the typical characteristics and problems of each catchment. Accordingly, although the EDSS-Besòs is not completely exportable to other catchments, we expect that the EDSS construction process and the used tools will be useful to develop any EDSS for water quality management at catchment scale.

## References

1. Poch, M., Comas, J., Rodríguez-Roda, I., Sànchez-Marrè, M., Cortés, U. Designing and Building Real Environmental Decision Support Systems. *Environmental Modelling and Software*. Vol. 19, 9. (2004) 857-873.
2. Fedra, K. Environmental Decision Support Systems: A Conceptual Framework and Application Examples. Thesis. (2000).
3. Luay, M. Decision-Support System for Domestic Water Demand Forecasting and Management. *Water Resources Management* 15. (2001) 363-382.
4. Cheng, H., Yang, Z., Chan, C.W. An Expert System for Decision Support of Municipal Water Pollution Control. *Engineering Applications of Artificial Intelligence*. Vol. 16. (2003), 159-166.
5. Comas, J., Alemany, J., Poch, M., Torrens, A., Salgot, A., Bou, J. Development of a Knowledge-based Decision Support System for Identifying Adequate Wastewater Treatment for Small Communities. *Water Science and Technology*. Vol. 48, 11-12. (2003) 393-400.
6. Froukh, M.L. Decision Support System for Domestic Water Demand Forecasting and Management. *Water Resources Management*. Vol. 15. (2001) 363-382.
7. Richards, J.S. A new era for EDSS? Water Ignites: a Fear of Farming. *Environmental Modelling and Software*. Vol. 18. (2003) 487-490.
8. Bondelid, T., Iliiev, P., McCarthy, M. RTI's River Management Decision Support System (RIMDESS). Research Triangle Institute. (1997).
9. Chang, Y.C., Chang, N.B. The Design of a Web-based Decision Support System for the Sustainable Management of an Urban River System. *Water Science and Technology*. Vol. 46, 6-7. (2002) 131-139.
10. Demissie, M., Guo, Y., Knapp, H.V., Bhowmik, N.G. The Illinois River Decision Support Management (ILRDSS). Illinois Department of Natural Resources. (1999).
11. Halls, J.N. River Run: an Interactive GIS and Dynamic Graphing Website for Decision Support and Exploratory Data Analysis of Water Quality Parameters of the Lower Cape Fear river. *Environmental Modelling and Software*. Vol. 18. (2003) 513-520.
12. Matthies, M., Berlekamp, J., Lautenbach, S., Graf, N., Reimer, S. Decision Support System for the Elbe River Water Quality Management. International Congress on Modelling and Simulation. Integrative modelling of biophysical, social and economic systems for resource management solutions. Modelling and simulation society of Australia and New Zealand Inc. (2003).
13. Quinn, N.W.T., Hanna, W.M. A Decision Support System for Adaptive Real-time Management of Seasonal Wetlands in California. *Environmental Modelling and Software*. Vol. 18. (2003) 503-511.
14. Schlaeger, F., Schonlau, H., Köngeter, J. An integrated Water Resources Management Approach for the River Spee and its Catchment. *Water Science and Technology*. Vol. 47, 7-8. (2003) 191-199.
15. Denzer, R. Generic Integration in Environmental Information and Decision Support Systems. International Environmental Modelling and Software Society. Proceedings. Vol. 3. (2002) 53-60.

16. Willems, P. Methodology for Integrated Catchment Modeling. IMUG Conference, Tilburg, 23-25 April (2003).
17. InfoWorks v5.5 copyright © 1997-2004 Wallingford Software Ltd.
18. Olsson, G., Newell, B. Wastewater Treatment Systems. Modelling, Diagnosis and Control. IWA publishing. London (1999).
19. Meirlaen, J., Van Assel, J., Vanrolleghem, P.A. Real Time Control of the Integrated Urban Wastewater System Using Simultaneously Simulating Surrogate Models. Waste Water and Technology. Vol 45, 3 (2002) 109-116.
20. Jakeman, A.J., Letcher, R.A. Integrated Assessment and Modeling: Features, Principles and Examples for Catchment Management. Environmental Modelling and Software. Vol. 18. (2003) 491-501.